

1

2

3

4

5

6

7

8

CHANGE

Revision

Date

Description

Approval

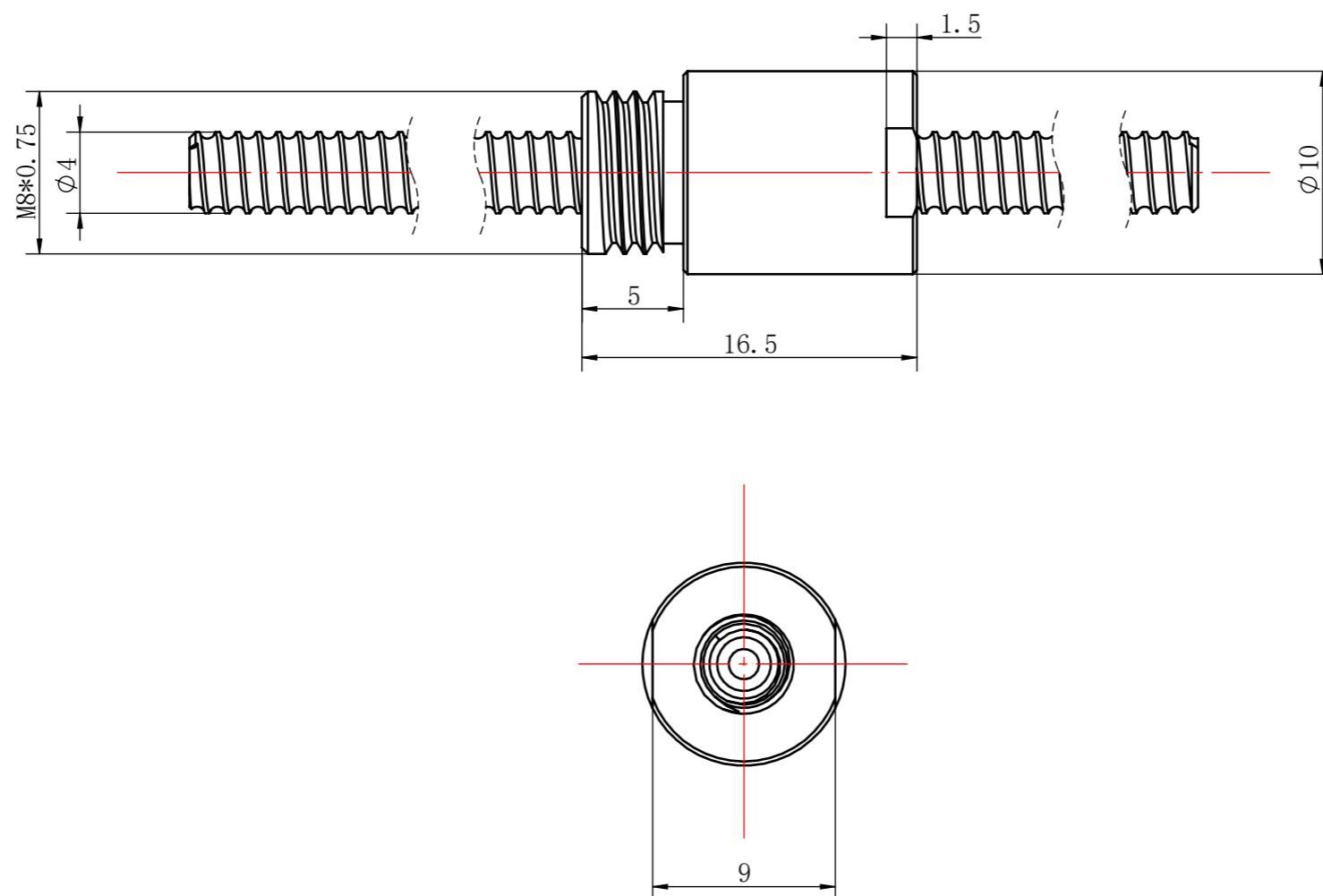

LINEAR		SPECIFICATION				CUSTOMER			
0.5~3	±0.1	B. C. D	Ø4.15	BALL SIZE	Ø0.8	C. MODLE			
>3~6	±0.1	SPACER BALL		LEAD	1	MODLE MBG0401			
>6~30	±0.2	ALLOW ROTATION NUMBER		LEAD ANGLE		NAME BALL SCREW			
>30~120	±0.3	LUBRICANT		NUMBER OF TURNSxROWS		WEIGHT			
>120~400	±0.5	O. C.	MAX. AXIAL Ca	THREAD DIRECTION/NUMBER OF THREAD		DESIGN			
>400~1000	±0.8		MAX. RPM		DYNAMIC Ca (N)	REV.			
>1000~2000	±1.2	L. A.			STATIC Coa (N)	SCALE			
ANGULAR					PRELORD TORQUE	UNITS		RATIFY	
~10	±1°				AXIAL PLAY	mm		TOTAL:	
>10~50	±30'				SCREW MATERIAL	PAGE:			
>50~120	±20'				NUT MATERIAL				
>120~400	±10'	ACCURACY GRADE:				JIANGSU DINGS' INTELLIGENT CONTROL			

1

2

3

4

5

6

7

8